



bat

¿Cómo se relaciona la ciudadanía con el urbanismo?

Enemigos

Interlocutores

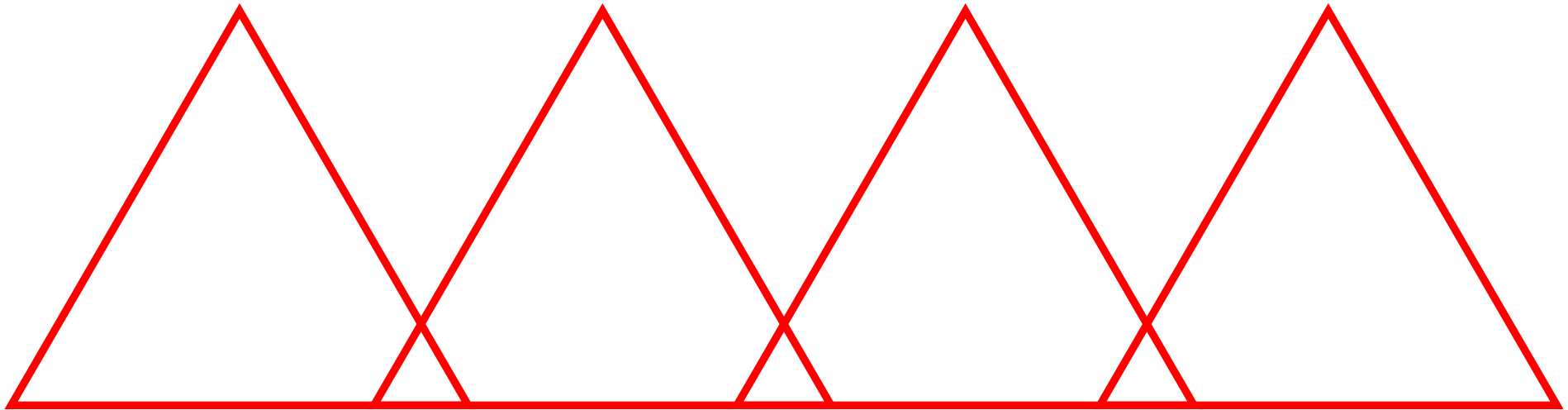

Adversarios

Competidores

París, 1853

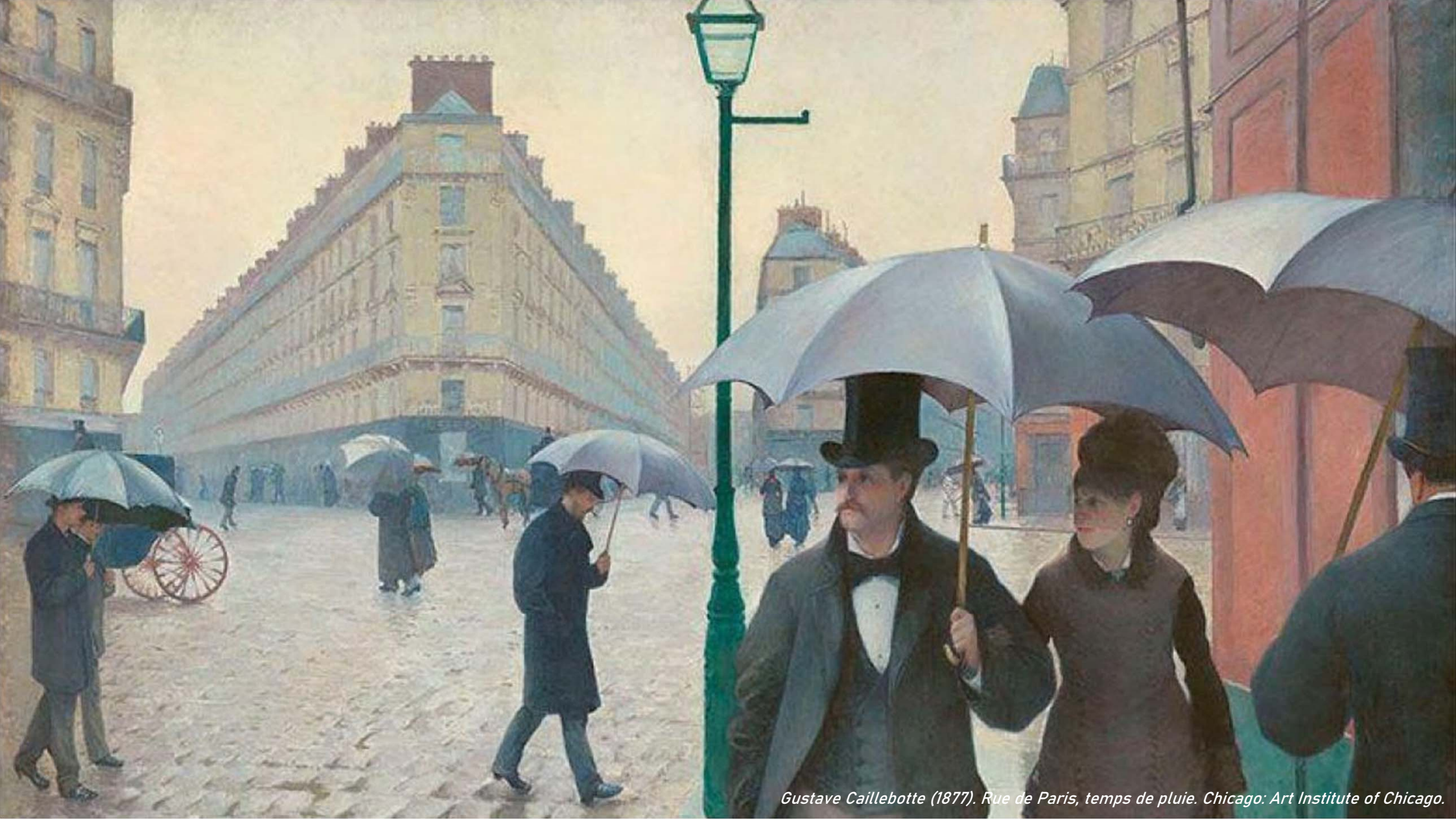

Gustave Caillebotte (1877). Rue de Paris, temps de pluie. Chicago: Art Institute of Chicago.



En, Speciator benevole, Magnifica Hispaniae ciuitas Bilbao, alijs, quasi Bellum vadum, Bilvao, vnde fit, vt alteram, per .V. sijnlabum, scribant, condita à Diadaco Lopeo de Haco, Cantabror. Principe, Anno circiter Millefimo, trecentesimo, à N. Ch. venusfa Hogenbergij manu, ad viuum delineata, ob oculos tibi ponitur, ea forma, qua anno Christi. MD. XL. IV. conspiciatur, Cuius eleganti icone, opus hoc nostrum beaur, Praecellens & eximus Vir, D. Joannes Mustin. Hispaniarum Regis. M. à sacris, summus praesantium picturarum, et antiquitatum, admirator.

LA VARA DE PORTO GALETE



- | | | |
|---------------------------|------------------------------|-------------------------------------|
| 1. S. Bartolome. | 9 La cendeja. | 16 Carniceria. |
| 2. S. Pedro de aluato. | 10 S. Niago. | 17 La yglesia de los SS. S. Juanes. |
| 3. S. Barbara. | 11 La casa de don Cristobal. | 18 S. Cruz. |
| 4. S. Vincente de aluato. | 12. S. Anton. | 19 La casa de los fragiles. |
| 5. La concecion. | 13. Arcealle. | |
| 6. S. Francisco. | 14. Tenderia. | |
| 7. S. Augustin. | 15. Oello os nealle. | |
| 8. Cay de la arena. | | |

La villa de Bilbao, por el flamenco Franz Hohenberg en 1554.



implosión-explosión
(concentración urbana, éxodo rural, extensión del tejido urbano, subordinación completa de lo agrario a lo urbano)



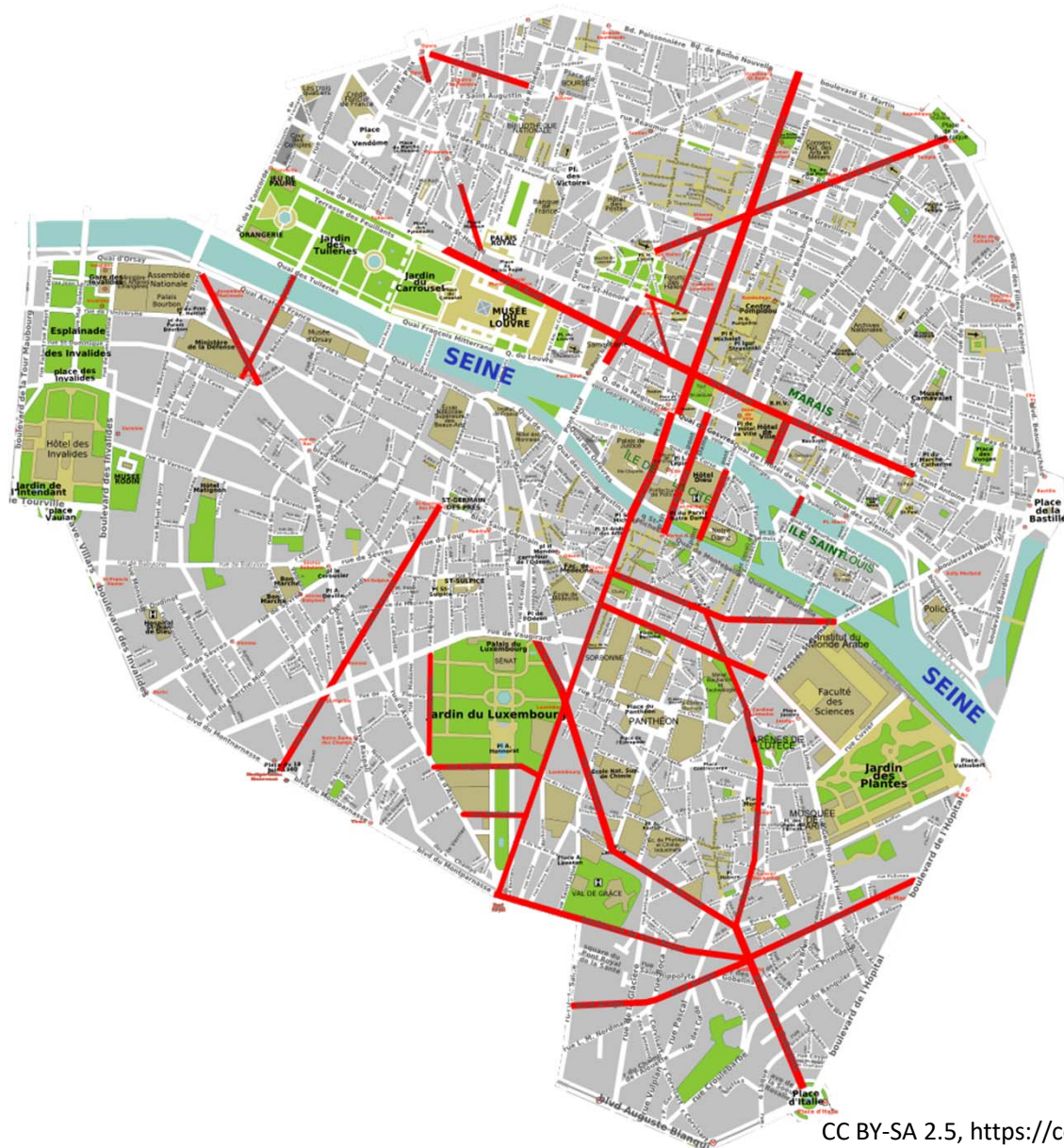





Gamonal del Río Pico, 2014









Fotógrafo: Rodrigo Mena Ruiz / @rodrigomenaruiz. Todos los derechos reservados



Porto Alegre, 1989





Fotografia de Aline Gonçalves.

Londres, 1988





Figura 2. Rascacielos construidos en New York City, 1890-2010

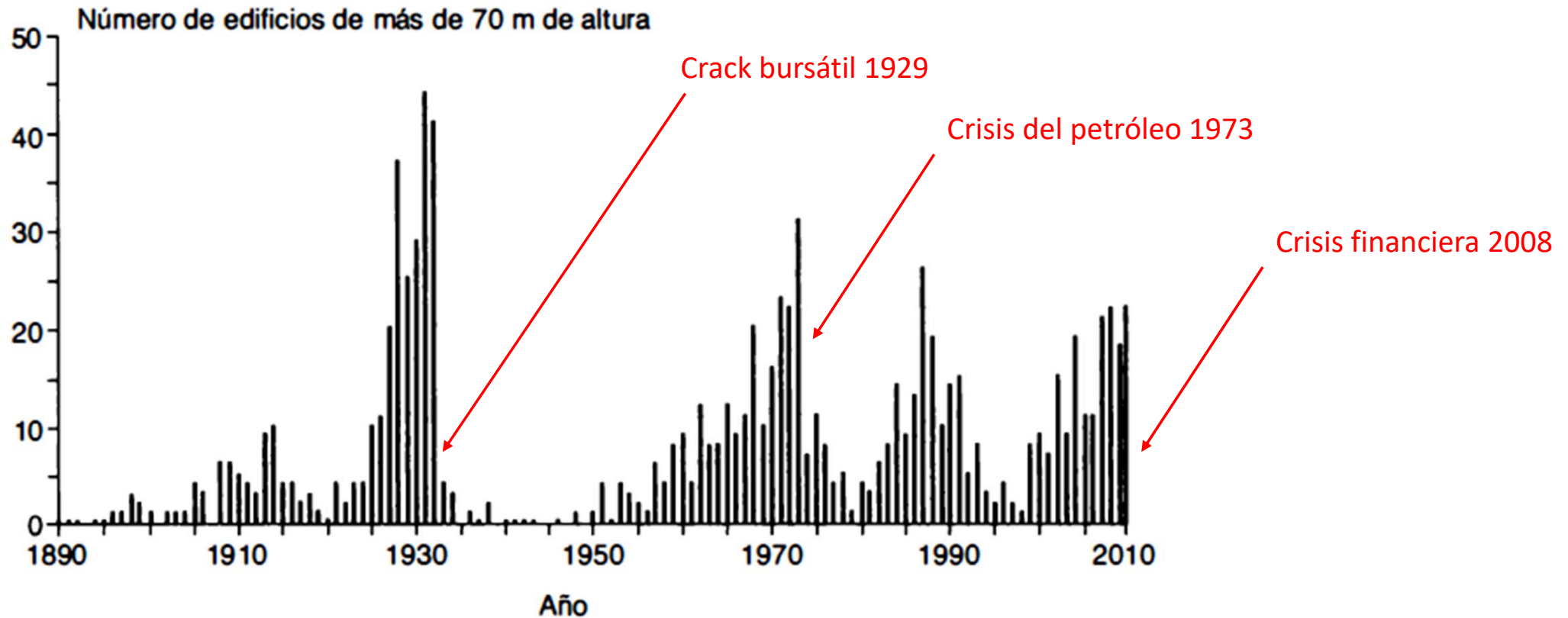

*Fuente: William Goetzmann y Frank Newman, «Securitization in the 1920s»,
NBER Working Paper 15650*

Relación de la ciudadanía ante el urbanismo

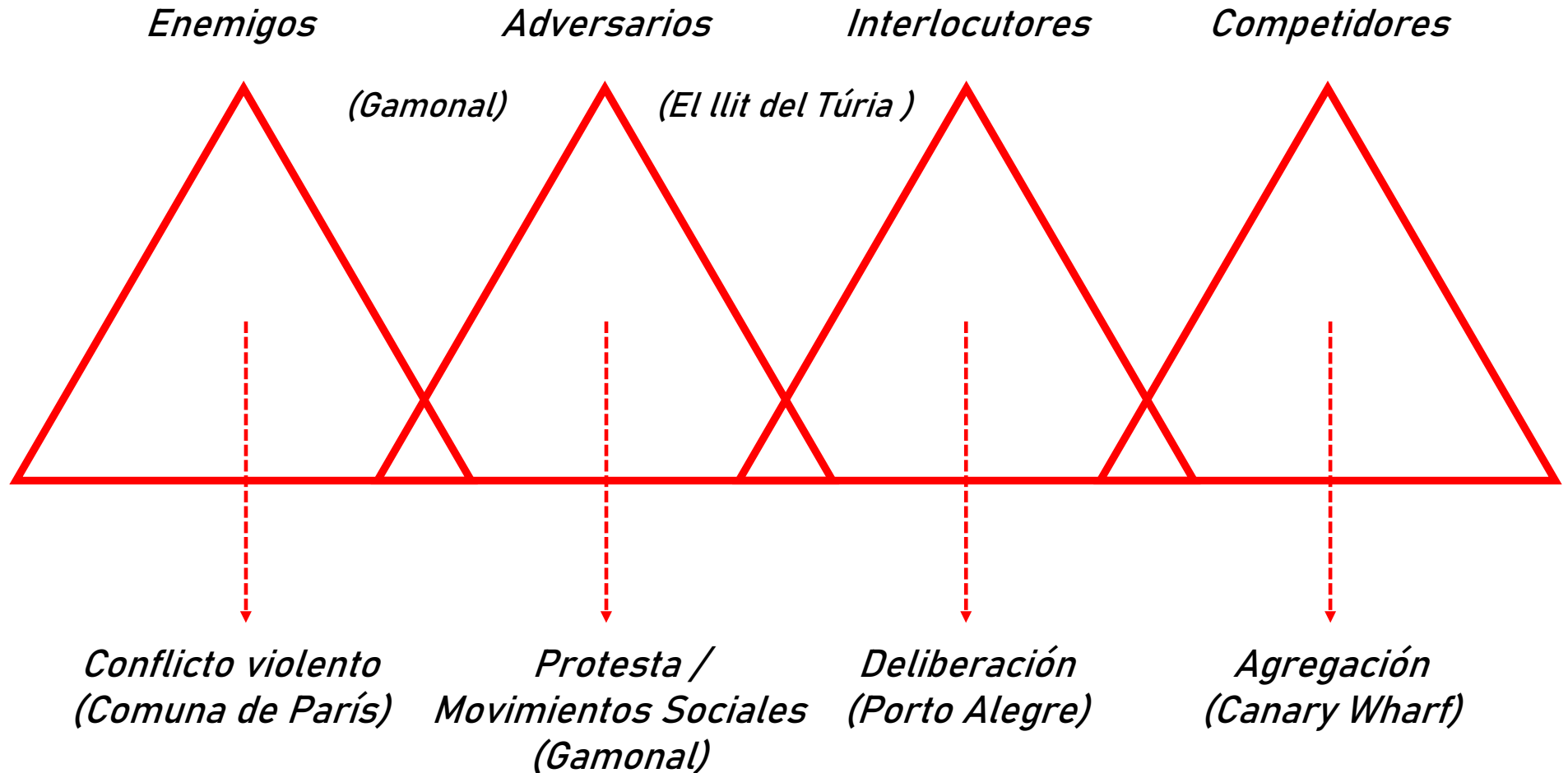



bi

Modernidad

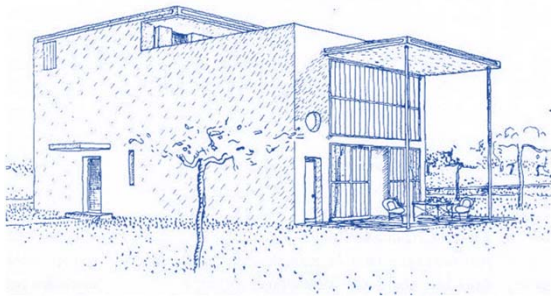

Pos
modernidad

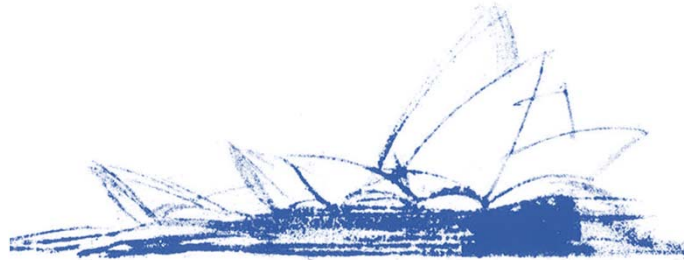

Contemporaneidad



Modernidad



Sujeto universal
Relato
Positivismo
Colectivo

**Pos
modernidad**



Sujeto individual
Experiencia
Pesimismo
Individualismo

Contemporaneidad



Sujetxs diversxs
Proceso
Participación
Gobernanza

Contemporaneidad



Sujetxs diversxs
Proceso
Participación
Gobernanza



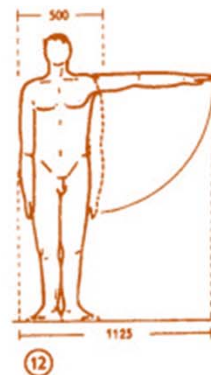
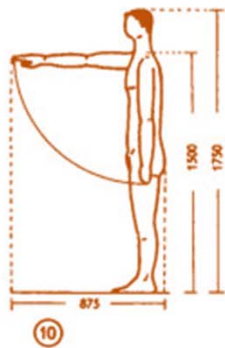
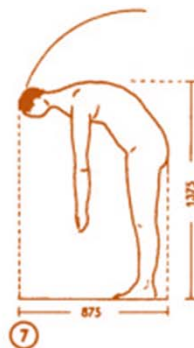
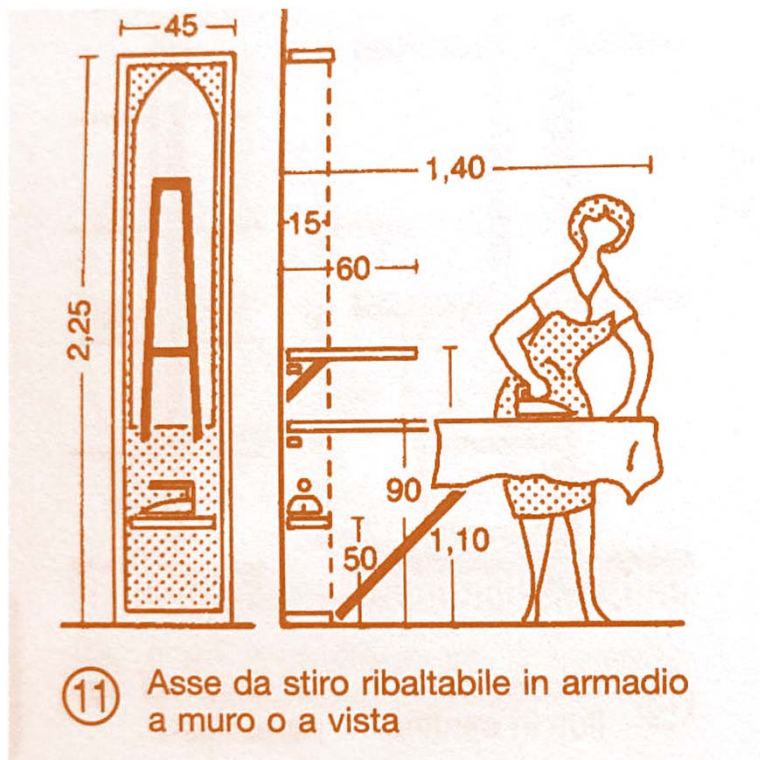



Fotografías de Mimmo Jodice.

Premodernidad \Rightarrow Sociedad preindustrial



Premodernidad \Rightarrow Sociedad comercial



Modernidad \Rightarrow Sociedad industrial

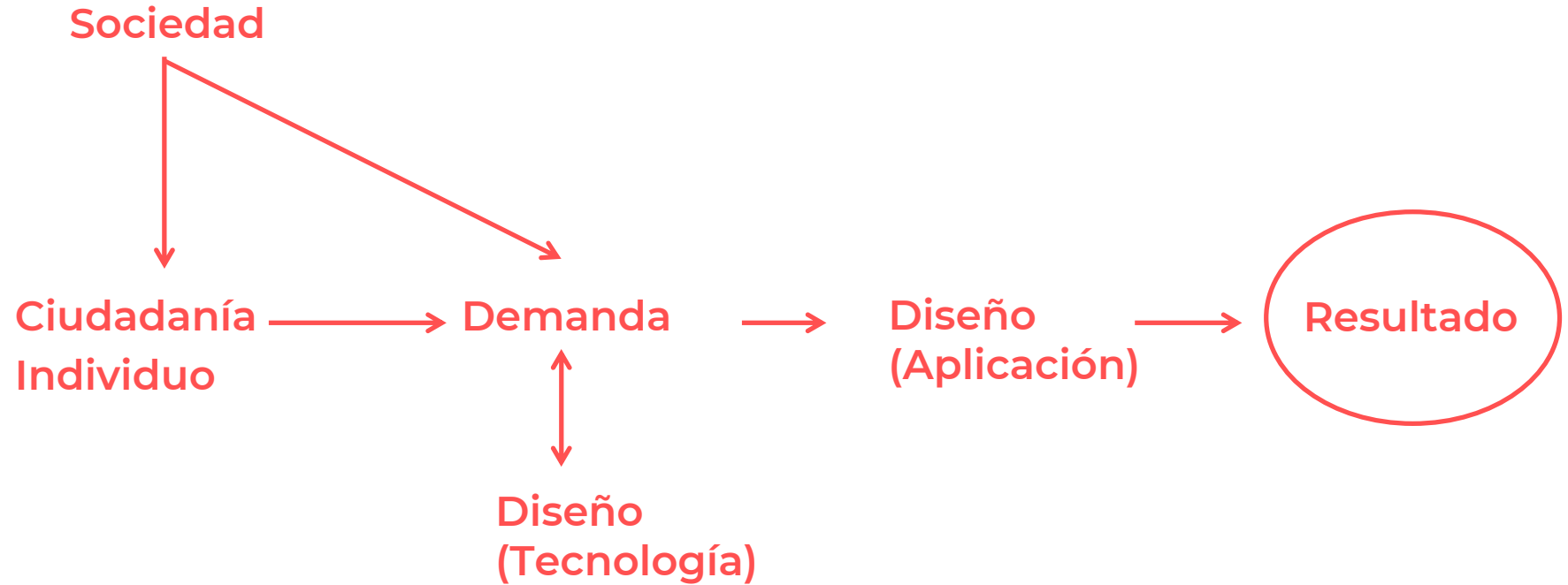

Posmodernidad \Rightarrow Sociedad posindustrial

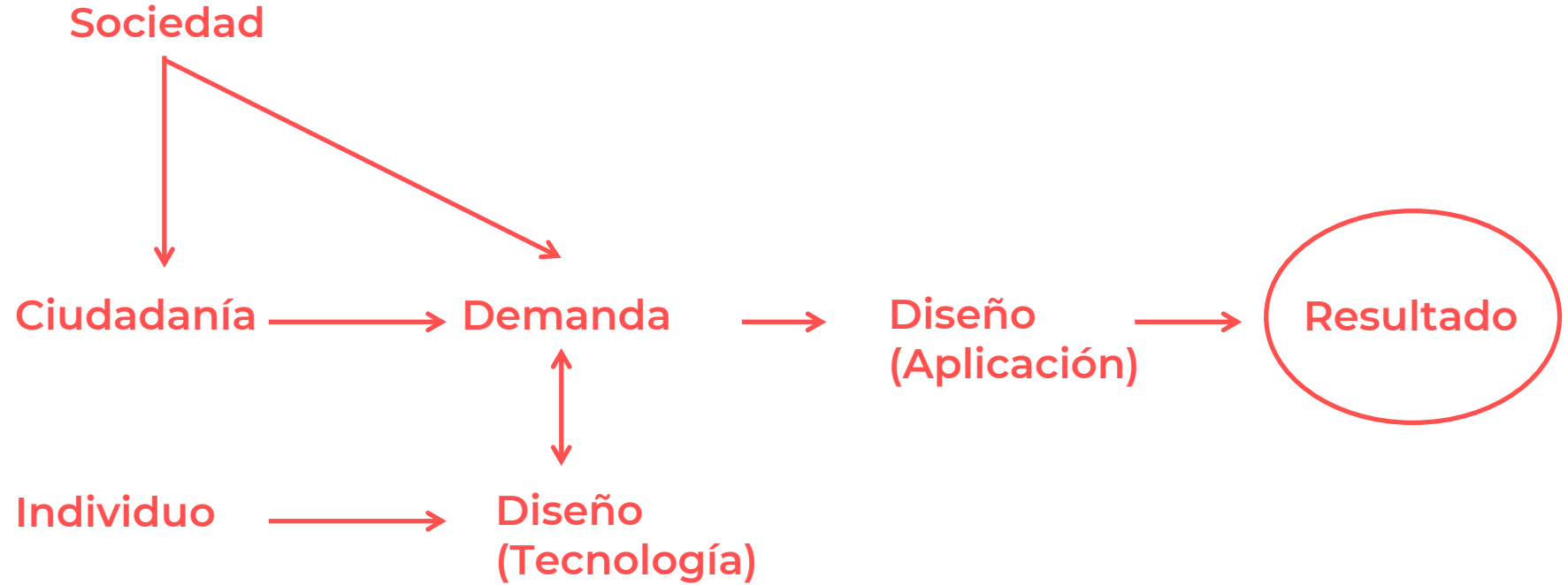

Contemporaneidad \Rightarrow ¿Actualidad?

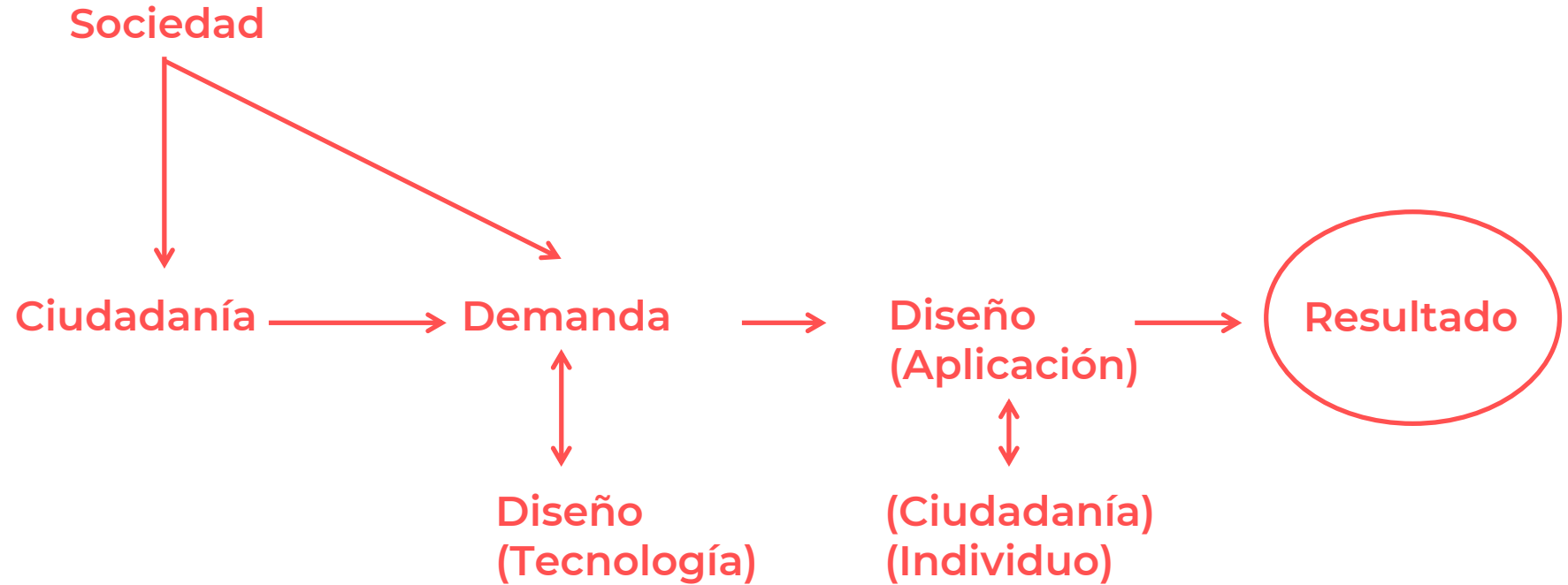

Contemporaneidad \Rightarrow ¿Actualidad?

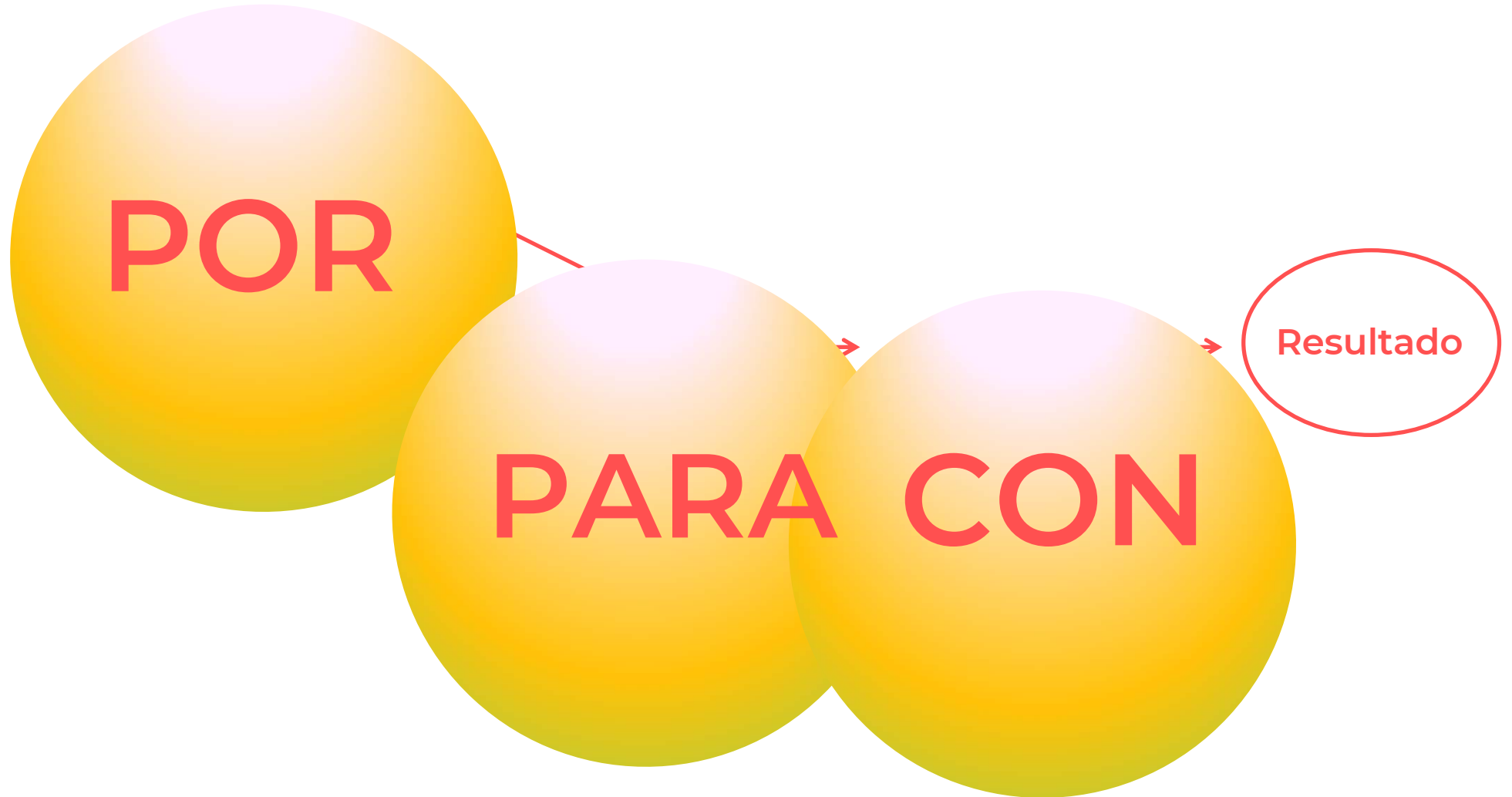



hiru



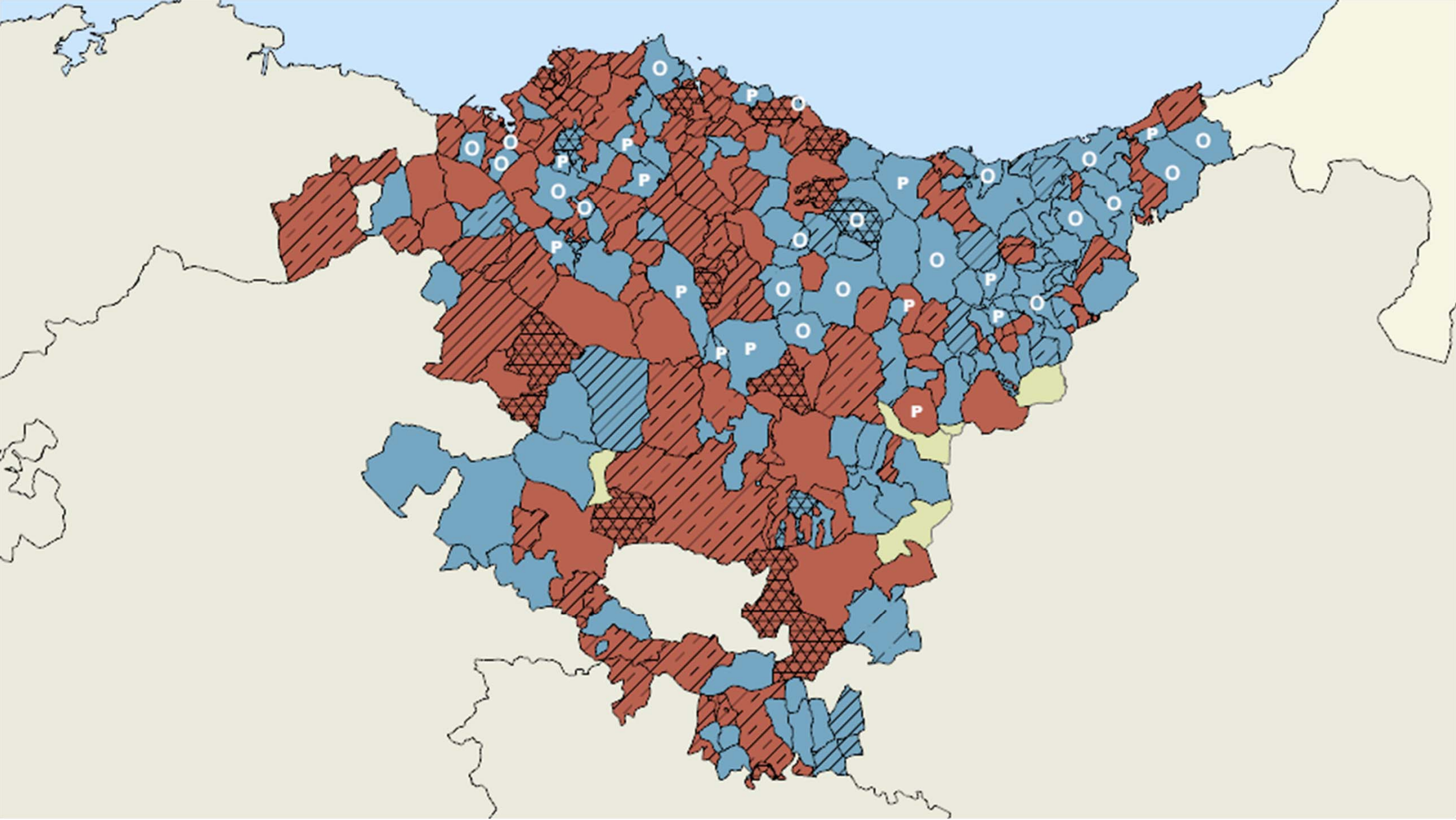

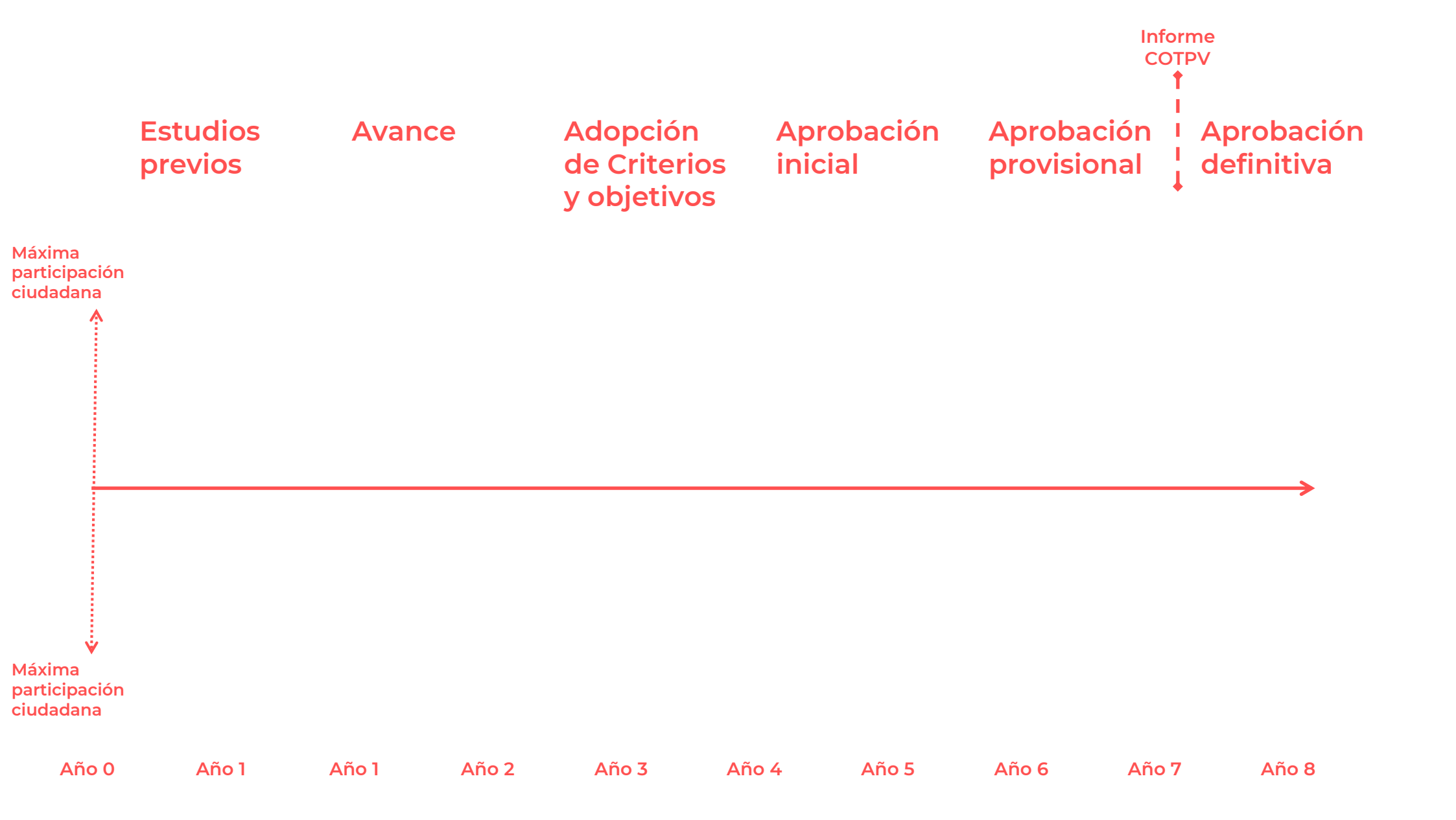

Estudios
previos

Avance

Adopción
de Criterios
y objetivos

Aprobación
inicial

Aprobación
provisional

Aprobación
definitiva

Informe
COTPV



Máxima
participación
ciudadana



Máxima
participación
ciudadana



Año 0

Año 1

Año 1

Año 2

Año 3

Año 4

Año 5

Año 6

Año 7

Año 8

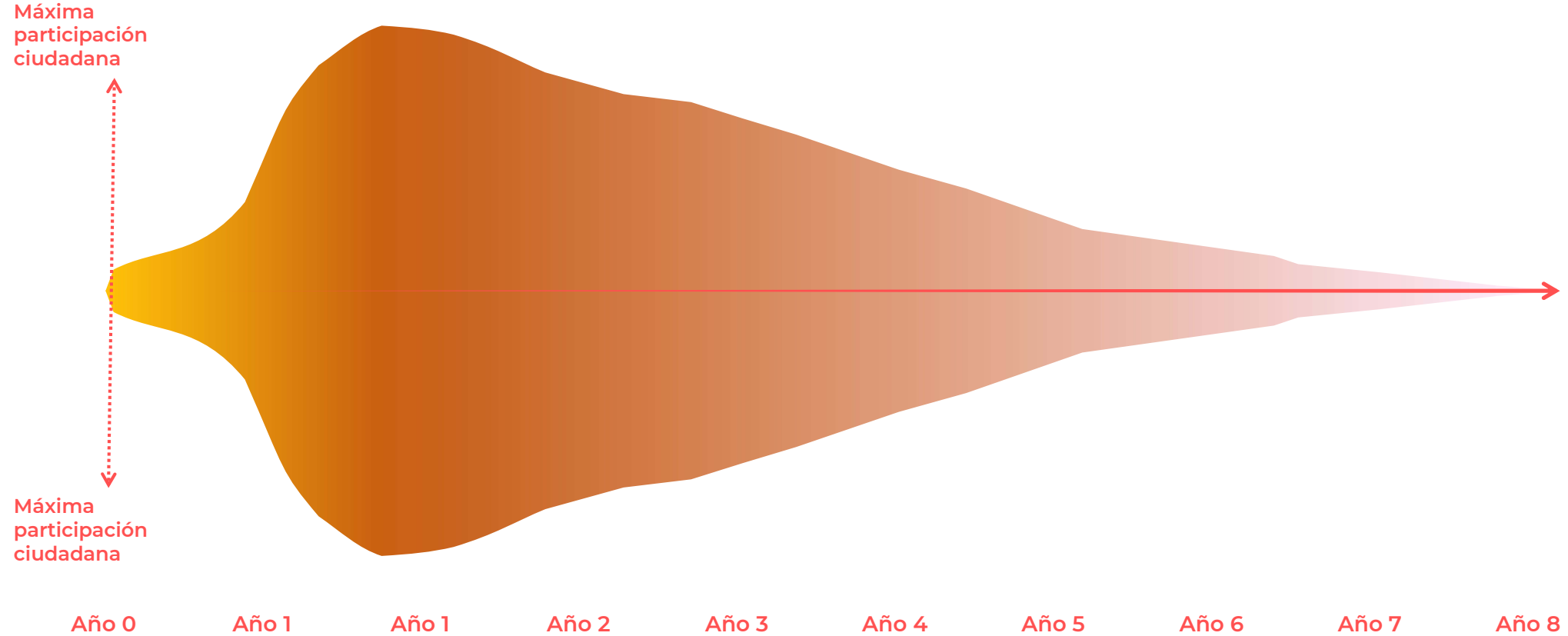

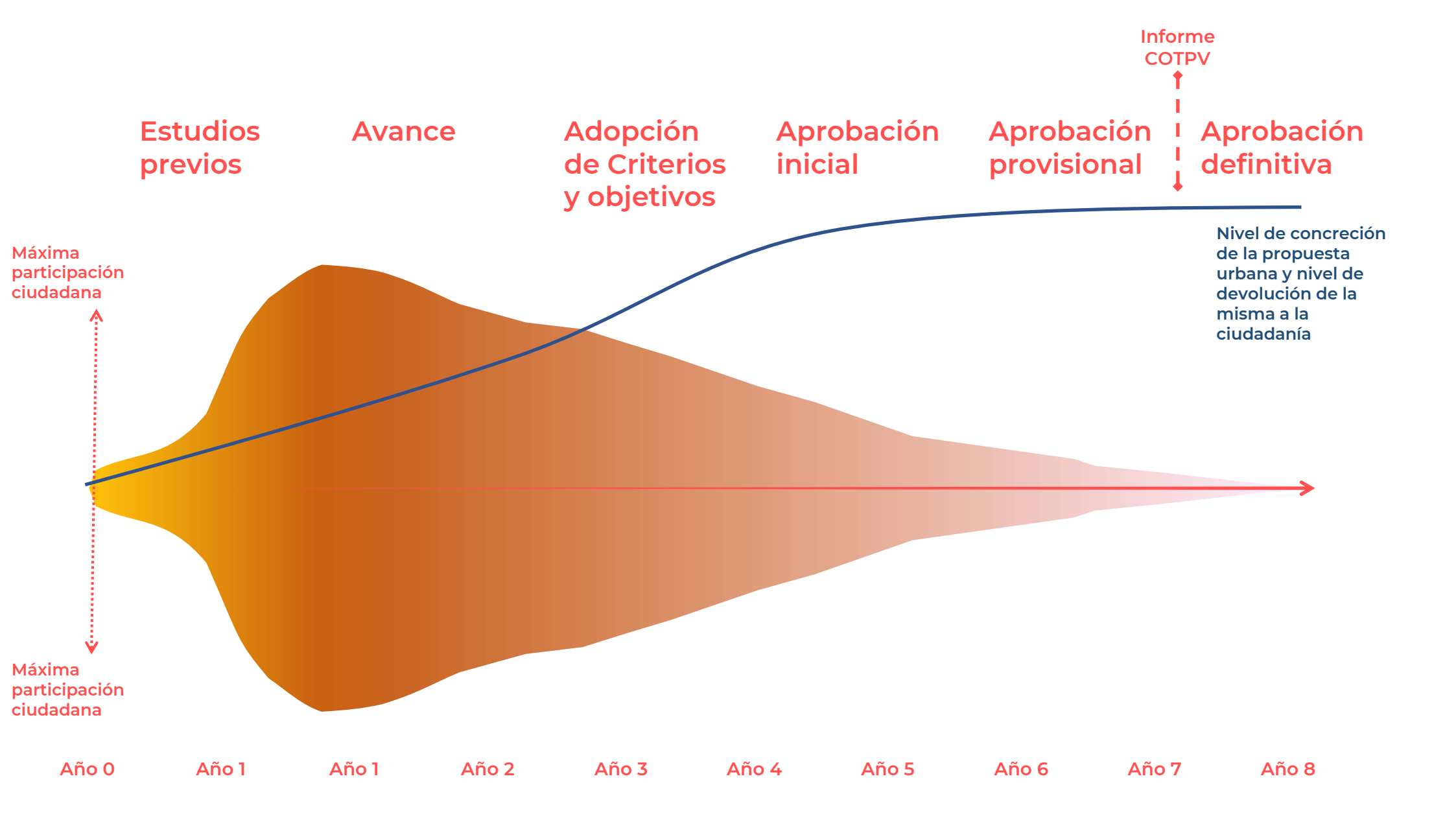

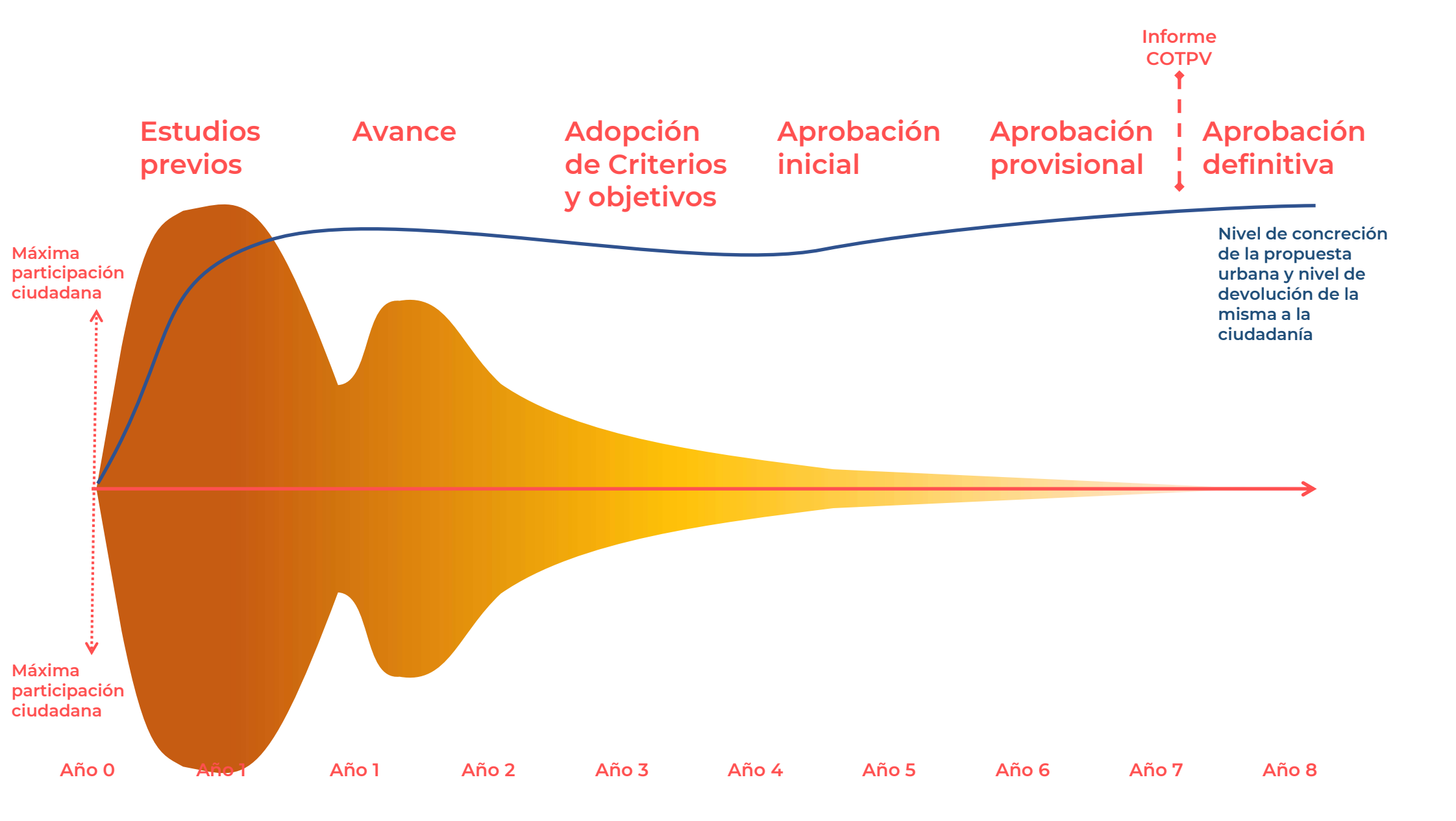



lau

Vectores de mejora

Definición clara de **límites y plazos**

Vectores de mejora

Esfuerzos extra en **devolución, información, explicación** (nuevas tecnologías, asistencia personalizada)

Vectores de mejora

Reducir el tiempo de participación, reducir la indeterminación del Plan (participar en la parte maleable del plan, no en la rígida).

Vectores de mejora

Reformulación de Consejos Asesores de Planeamientos Municipales, como asamblea permanente, o búsqueda de **modelo consultivo transversal y alternativo.**

Vectores de mejora

Adopción de **herramientas digitales** que permitan una participación masiva.

ADI! BULEGOA

ARKITEKTURA
DISEINUA
IDEIAK



ADI! BULEGOA ~ ARKITEKTURA · DISEINUA · IDEIAK

Koop. Elk. Txikia P.

adi@adi-bulegoa.com